

Depth log interface

Product reference : 90-60-450



INSTALLATION GUIDE

nke – Sailing competition

Z.I. Kerandré – Rue Gutenberg – 56700 HENNEBONT- FRANCE
<http://www.nke.fr> – n° indigo 0 892 680 656 : 0,34€/min.

TABLE OF CONTENTS

1	PRESENTATION.....	3
2	TECHNICAL SPECIFICATIONS	4
3	DIAGNOSTIC FOR 1ST LEVEL TROUBLESHOOTING.....	4
4	INSTALLATION.....	5
4.1	LIST OF ACCESSORIES	5
4.2	INSTALLATION PRECAUTIONS.....	5
4.3	INSTALLATION OF THE DEPTH-FINDER LOG INTERFACE HOUSING	5
4.4	CONNECTION TO THE <i>TOPLINE</i> BUS.....	6
4.5	CONNECTION OF THE SENSORS	6



2 TECHNICAL SPECIFICATIONS

- Power supply : 10 to 16VDC
- Consumption : 60mA
- Tightness :IP54
- Weight : 160 g
- Operating temperature : -10°C to +50°C
- Storage temperature : -20°C to +60°C

3 DIAGNOSTIC FOR 1ST LEVEL TROUBLESHOOTING.

This chapter can help you rapidly resolve minor problems which do not require the intervention of a specialist. Before contacting technical support, please check the troubleshooting table below.

Problem	Possible causes and solutions
The Topline installation does not detect the Depth-finder log interface	The bus cable is not or is badly connected to the terminal box : check the plugging and the connection inside the terminal box. Check the state of the cables : they must not show any sign of wear or cut.
The surface speed displayed is 0.00 , no matter what the speed of the ship is.	Check that the vaned rotor is not clogged (algae, seashells). Check that the calibration coefficient is not set to 0.00 : see chapter 3.
The surface speed displayed is 0.00 and the water temperature channel displays « Pan ».	It may be that the log sensor is badly connected or broken. Check the state of the cable and the connection to the box.
The depth-finder displays depth but the display flickers intermittently.	Your depth-finder is struggling to detect the seabed ; clean the surface of the depth-finder sensor.
The depth-finder continuously displays a constant depth : example 2.10	It may be that the depth-finder is detecting the keel and not the seabed. Please refer to the installation guide of the depth-finder sensor.
Your display indicates battery fault .	Check the voltage of your battery with a voltmeter : the operating voltage must be above 10VDC. Check that the battery maintains the load.

If you do not manage to solve the problem, please contact your distributor.

4 INSTALLATION

4.1 List of accessories

- 15 meter bus cable fitted with a connector : 90-60-460
- TOPLINE Terminal box : 90-60-121
- Cable adapter for old version of depth-finder sensor 90-60-453.
- Cable adapter for old version of vaned rotor log sensor : 90-60-454
- TOPLINE bus connector : 90-60-465.

4.2 Installation precautions

It is recommended to mount this housing towards the bow of the ship and at a certain height, in a location that is unlikely to get flooded.

4.3 Installation of the depth-finder log interface housing

The housing of the **depth-finder log interface** is splash-proof. It is fitted with three connector sockets for the connection of the depth-finder sensor, the log sensor and the TOPLINE bus cable. The housing will be mounted using four M4 screws (not included).

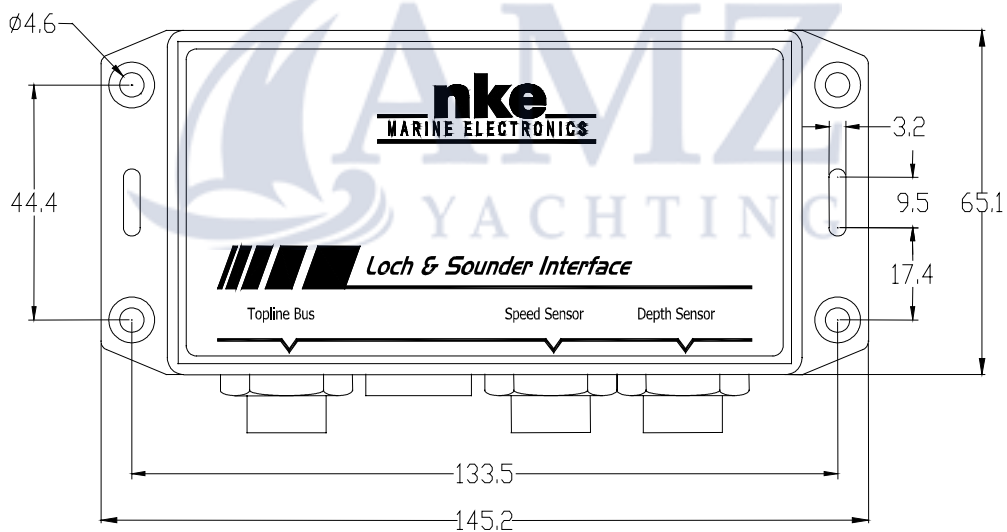

Figure 2

CAUTION :

- To guarantee the watertightness of the **depth-finder log interface**, make sure the connectors are firmly screwed onto the connector sockets.
- The connection of the sensors must be performed with the installation power switched off.

4.4 Connection to the *Topline* bus

1. Make the bus cable run from the **depth-finder log interface** to the **TOPLINE** terminal box of your installation.
2. Connect the bus cable inside the terminal box.

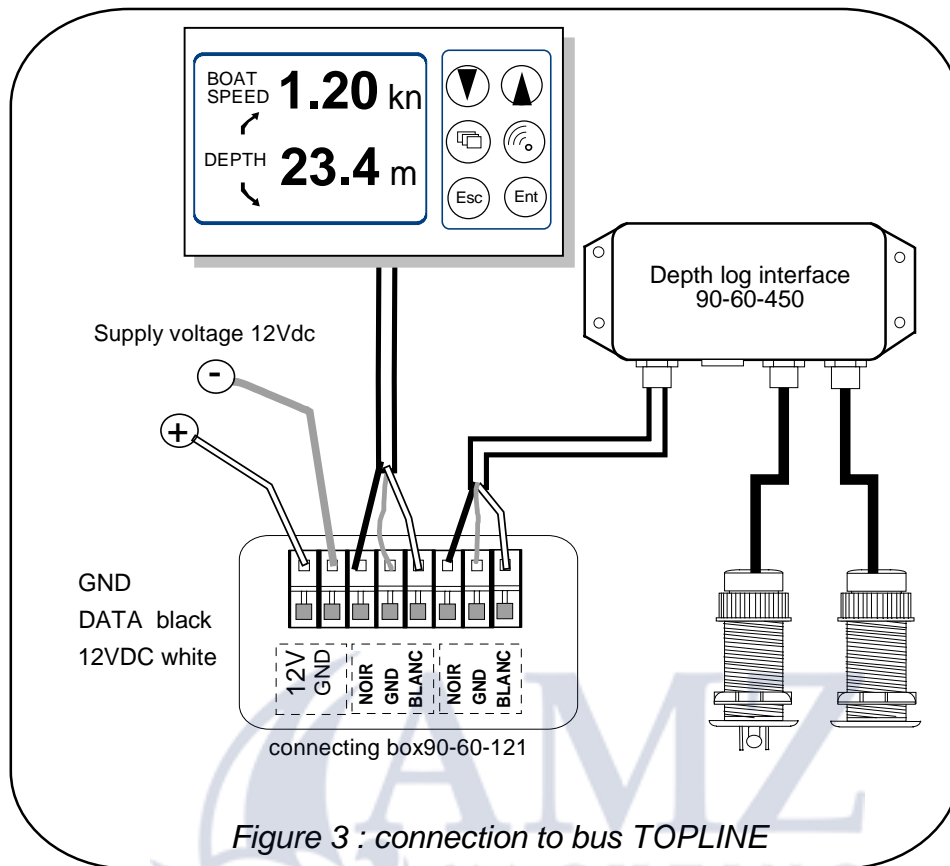

If you reduce the length of the bus cable 90-60-460, strip and galvanise the wires before connecting them inside the terminal box.

4.5 Connection of the sensors

The sensors are equipped with a 6 meter cable and a moulded waterproof connector. You will connect the speedometer log sensor, vanned rotor or electromagnetic, onto the connector socket marked **speed sensor** and the depth-finder sensor onto the **depth sensor** connector socket (see figure 2).

